

# LINED BEND

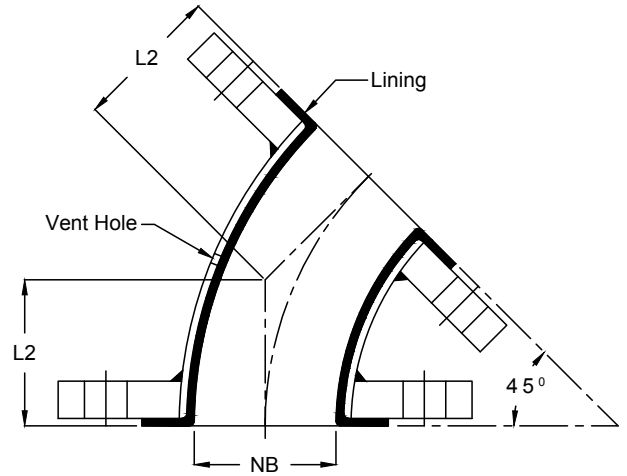
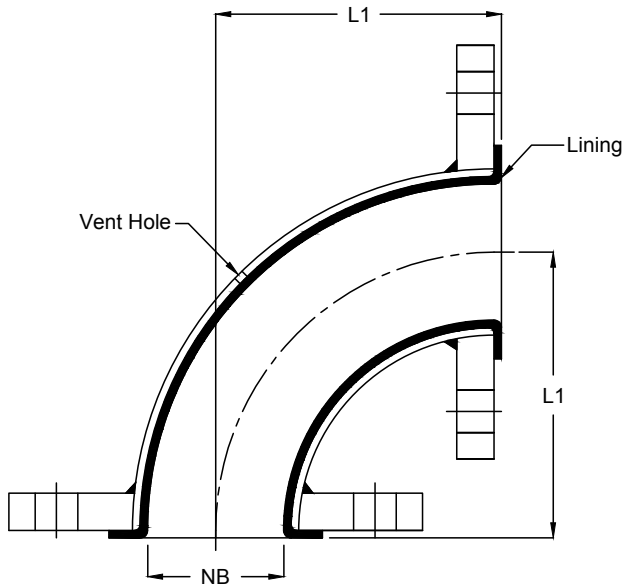

Dimension detail			
Size	Inch	L1	L2
NB	Inch	L1	L2
25	1"	89	45
40	1½"	102	57
50	2"	114	64
80	3"	140	76
100	4"	165	102
150	6"	204	127
200	8"	228	140
250	10"	279	165
300	12"	305	190

### Specification:

- Body:
- Steel Fabrication ASTM A234 Gr. WPB with Flange as per ASTM A105 / IS 2062,
  - Ductile Iron GGG40.3 / ASTM A395,
  - Cast Steel ASTM A216 Gr. WCB.

Flange: ANSI B16.5 / B16.42

Optional: Rotating Flanges on Request

Face To Face: ANSI B16.5 #150

Lining: PTFE / FEP / PFA / HDPE / PP / PVDF

Lining Thickness: 3mm to 7mm

Inspection & Testing: ASTM F1545-97

Hydraulic Test: 25 Kg/Cm<sup>2</sup>

Spark Test: 15 Kv

